

CT Series

Turbine flow meters with conditioned output

The CT turbine flow meter with conditioned output provides a complete solution to the flow measurement of hydraulic systems on test stands, machine tools and other fixed or mobile applications. The flow meter can be installed anywhere in the hydraulic circuit for production testing, commissioning, development testing and analysis of control systems. The compact design allows the CT series flow meters to be installed where space is limited.

The CT turbine flow meter has a built-in micro-controller that conditions the signal from the flow meter to provide an accurate analogue output. This enables the flow meter to be directly connected to a digital display, PLC or custom DAQ system without having to worry about complex calibration factors or lookup tables. Two versions are available offering 4 - 20 mA current loop or 0 - 5 V.

The CT flowmeter is the ideal tool for monitoring the performance of pumps, motors, valves, and hydrostatic transmissions.

See CTA series for automotive ready hydraulic system flow monitors with J1939 interface.

Specifications

Maximum Rated Pressure:	480 bar, 6,960 psi
Maximum Flow:	1,500 L/min, 396 US gpm
Ambient Temperature Range:	5 to 40°C, 41 to 104°F
Fluid Temperature Range:	5 to 90°C, 41 to 194°F
Compatible Fluids:	Mineral oils to ISO 11158. Other fluids consult sales office.
Porting:	BSPP, SAE
Material:	Aluminium
Body Materials:	Aluminium, Steel, Stainless Steel
Internal Materials:	Aluminium, Steel, Stainless Steel
Seals:	FKM (EPDM seals consult sales office)
IP Rating:	IP66
Power Supply:	12-32 VDC

ISO Symbol:

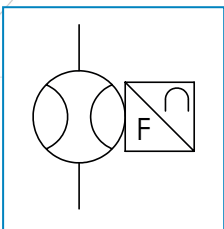

Make it **BLUE**

Features

- Bi-Directional operation.
- Wide range of hydraulic oil, lubrication oils, and fuels.
- Comprehensive range of accessories available including pressure and temperature transducers, panel meters and cables. For details consult our sales office.
- Output options 4-20 mA or 0-5 V.

Sales Order Code

Please contact our technical sales team to discuss any special order requirements.

MODEL NUMBER	OUTPUTS AVAILABLE	MAIN PORTS	TOP PORTS	CALIBRATED FLOW RANGE	MAX RATED PRESSURE
CT15-**-B-B-6	5V, mA	1/2" BSPP	1/4" BSPP	1-15 L/min	420 bar
CT15-**-S-S-6	5V, mA	3/4" -16UN #8 SAE ORB	7/16" -20UN #4 SAE ORB	0.25-4 US gpm	6000 psi
CT60-**-B-B-6	5V, mA	3/4" BSPP	1/4" BSPP	3-60 L/min	420 bar
CT60-**-S-S-6	5V, mA	1-1/16" -12UN #12 SAE ORB	7/16" -20UN #4 SAE ORB	0.8 - 16 US gpm	6000 psi
CT150-**-B-B-6	5V, mA	3/4" BSPP	1/4" BSPP	5-150 L/min	420 bar
CT150-**-S-S-6	5V, mA	1-1/16" -12UN #12 SAE ORB	7/16" -20UN #4 SAE ORB	1.3 - 40 US gpm	6000 psi
CT300-**-B-B-6	5V, mA	1" BSPP	1/4" BSPP	8 - 300 L/min	420 bar
CT300-**-S-S-6	5V, mA	1-5/16" -12UN #16 SAE ORB	7/16" -20UN #4 SAE ORB	2 - 80 US gpm	6000 psi
CT400-**-B-B-6	5V, mA	1" BSPP	1/4" BSPP	10 - 400 L/min	420 bar
CT400-**-S-S-6	5V, mA	1-5/16" -12UN #16 SAE ORB	7/16" -20UN #4 SAE ORB	2.5 - 100 US gpm	6000 psi
CT600-**-B-B-5	5V, mA	1-1/4" BSPP	1/4" BSPP	15 - 600 L/min	350 bar
CT600-**-F-S-3	5V, mA	1-1/2" #24 SAE Code 61 4-bolt flange	7/16" -20UN #4 SAE ORB	5 - 160 US gpm	3000 psi
CT600-**-S-S-5	5V, mA	1-5/8" -12UN #20 SAE ORB	7/16" -20UN #4 SAE ORB	4 - 160 US gpm	5000 psi
CT800-**-S-B-7	5V, mA	1-7/8" -12UN #24 SAE ORB	1/4" BSPP	20 - 800 L/min	480 bar
CT800-**-S-S-7	5V, mA	1-7/8" -12UN #24 SAE ORB	7/16" -20UN #4 SAE ORB	5 - 210 US gpm	7000 psi
CT800-**-F-B-3	5V, mA	1-1/2" #24 SAE Code 61 4-bolt flange	1/4" BSPP	20 - 800 L/min	210 bar
CT800-**-F-S-3	5V, mA	1-1/2" #24 SAE Code 61 4-bolt flange	7/16" -20UN #4 SAE ORB	5 - 210 US gpm	3000 psi
CT800-**-F-B-6	mA	1-1/2" #24 SAE Code 62 4-bolt flange	1/4" BSPP	20 - 800 L/min	420 bar
CT1500-**-F-S-6	5V, mA	2" #32 SAE Code 62 4-bolt flange	7/16" -20UN #4 SAE ORB	13.5 - 400 US gpm	6000 psi
CT1500-**-F-S-6-L	5V, mA	2" #32 SAE Code 62 4-bolt flange	7/16" -20UN #4 SAE ORB	50 - 1500 L/min	420 bar

Notes

Replace ** with the outputs available code to give complete model number.

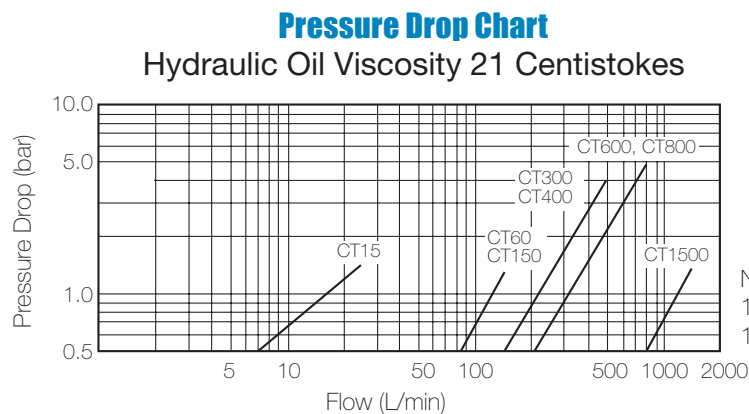

Installation Details

Model No	A		B		C		D		E		Weight	
Units	mm	in	mm	in	mm	in	mm	in	mm	in	kg	lb
CT15	37	1-1/2"	136	5-3/8"	37	1-1/2"	123	5"	69.5	2-3/4"	0.7	1.50
CT60	62	2-1/2"	190	7-1/2"	50	2"	136	5-3/8"	103	4"	1.6	3.50
CT150	62	2-1/2"	190	7-1/2"	50	2"	136	5-3/8"	103	4"	1.6	3.50
CT300	62	2-1/2"	190	7-1/2"	50	2"	140	5-1/2"	103	4"	1.7	3.70
CT400	62	2-1/2"	190	7-1/2"	50	2"	140	5-1/2"	103	4"	1.7	3.70
CT600	62	2-1/2"	212	8-3/8"	75	3"	152	6"	127	5"	2.7	6.00
CT600-**-F-**-*	100	4"	212	8-3/8"	75	3"	152	6"	126	5"	5	11.00
CT800	100	4"	212	8-3/8"	75	3"	152	6"	126	5"	5	11
CT800 (CODE 62)	113	4-1/2"	212	8-3/8"	100	4"	165	6-1/2"	126	5"	6	13.2
*CT1500	140	5-1/2"	260	10-1/4"	100	4"	176	7"	130	5-1/8"	10	22

*CT1500 includes 4 feet on base, add 20 mm (3/4") to D for full height.
CT1500 is fitted with carry handles - not shown on diagram

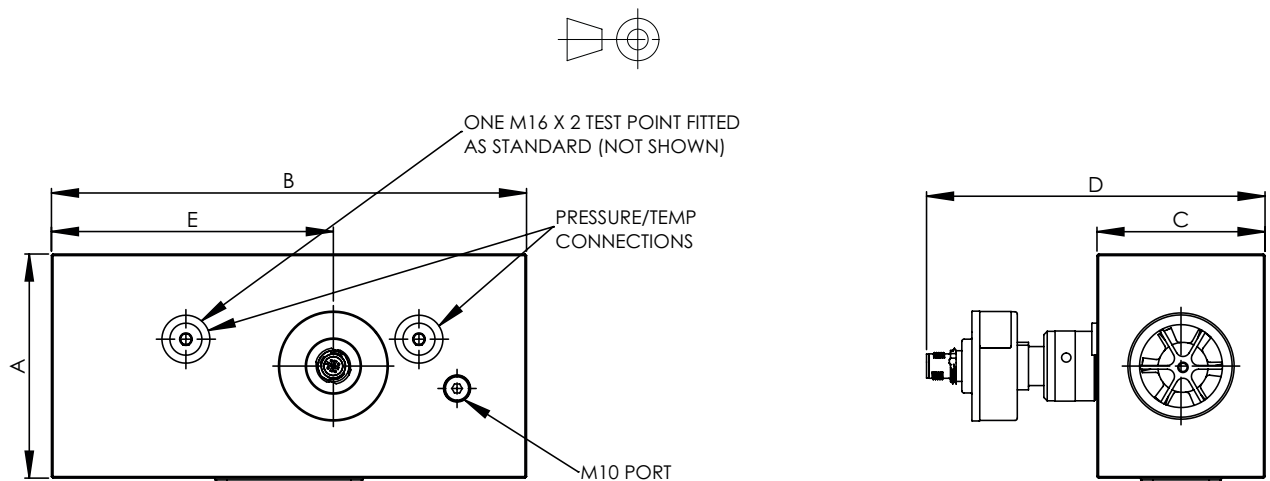

Connecting Details

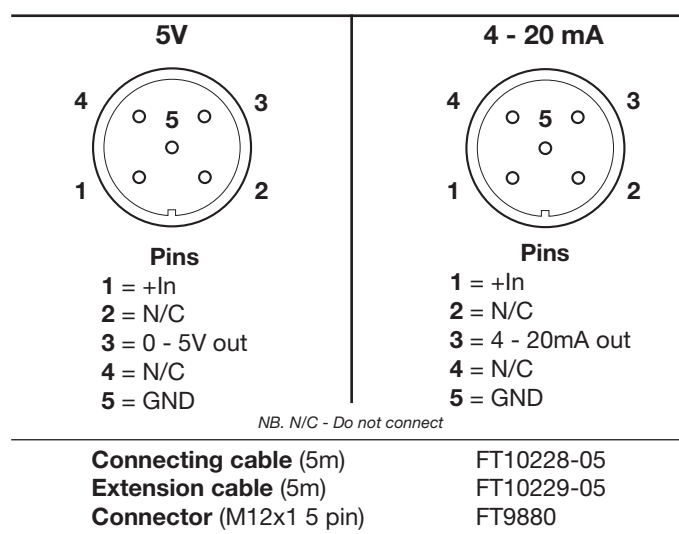

Functional Specification

Accuracy:	Reading 15% to 100% of flow range - 1% of indicated reading. Readings below 15% of full scale flow - fixed accuracy of 0.15% of full scale (CT15 is 1% of full scale).
Repeatability:	Better than $\pm 0.2\%$
Response Time:	50 m/s + 1 period (of turbine frequency)
Degree of protection:	CT-mA, CT-5V - IP66 (EN60529) With cable connected.

Electrical Specification

Supply voltage (VS):	mA & 5V = 12 - 32 VDC
Current output:	4 - 20 mA, 3 wire loop, max loop resistance = (VS x 50) - 200 ohms
Voltage output:	0 - 5 VDC, current consumption = 10 mA, minimum load 20K ohms
Zero & FSD:	4mA and 0V = zero flow 20mA, 5v = FSD
Over-range:	+5% FSD (20.8mA, 5.25v)

Construction Materials

Flow body:	600/800/1500 High tensile Aluminium 2014A T6 15/60/150/300/400 High tensile Aluminium 2011 T6 15 High tensile Aluminium 6082 T6
Transducer:	Body and nut -steel 212A42 electroless nickel plated Housing and Lid - Aluminium 2011 T3 electroless nickel plated
Cable:	Cable jacket - Polyurethane Nut - nickel plated Zinc Contact - Brass

Operation

As fluid is passed through the flow block it rotates a precision turbine. The flow straighteners and turbine design minimise the effects of turbulence and swirl. The turbine blades are detected by a magnetic reluctance transducer and the frequency is captured by a micro-controller. The micro-controller converts the frequency in to the calibrated output signal available at the connector. The flow block has ports for pressure or temperature sensors which can be supplied as an option.

Reverse Flow

The flow block is capable of measuring flow in either direction.

Calibration

All CT turbine flow meter are calibrated at a mean viscosity of 21cSt using ISO32 hydraulic mineral oil to ISO11158 category HM. Calibration certificates are available on request - this is a chargeable option. Production calibration of CT1500 L/min turbine is confirmed by testing over the range of 50 to 750 L/min and by design only above 750 L/min. Other calibration on request - please consult the sales office.

Installation

The flow block has built-in flow straighteners so the normal recommended length of 10 Ø of straight tube can be reduced to 8Ø where space is limited. Inlet and outlet connections should always be of a similar bore size to that of the flow block to prevent venturi or constriction effects.

The range of flow meters can be used for intermittent or continuous testing of flow in either direction. The flow block can be mounted in any orientation. For heavy duty applications where the flow block will be used constantly with continuous pressure spikes please contact sales to discuss your application.

Filtration

Must be better than DIN ISO4406: 21/19/16 or NAS 10 (typically achieved with 20-20u filters).
CT15; must be better than DIN ISO4406: 19/16/13 or NAS 7 (typically achieved with 10u filters).

Top ports

Most flow meters have two additional ports (see table for configuration) in the top face of the flow meter to enable the user to connect both a temperature and pressure sensor. The CT15 has one top port. All flow blocks come with one M16 x 2 test point fitted as standard.

Turbine Flow Meters

Accuracy

The accuracy is better described as the uncertainty of the flow reading compared to a known reference. Every flow measurement has an error associated with it, caused by the combination of a large number of factors that affect the operation of the flow meter, these include bearing friction, temperature, viscosity, magnetic drag and the signal strength to name but a few.

All our flow meters are calibrated at 10 points over the flow range and its performance measured against a flow reference that is traceable to International standards. Accuracy is typically quoted in one of two ways: as a percentage of full scale (the maximum calibrated flow) or as a percentage of the indicated reading (the actual flow).

Full scale (FS) or full scale deflection (FSD)

A term that was originally used for analogue displays where a needle pointed to a number on a scale, hence FSD. The flow accuracy is a fixed amount regardless of the actual flow you are measuring. For example 1% FS for a flow meter with a maximum calibrated flow of 400 L/min is ± 4 L/min whether you are measuring 40 L/min, 200 L/min or 400 L/min (see graph below). If you need to measure flows of 40 and 400 L/min with same flow meter then it is important to check the allowable error at all flows.

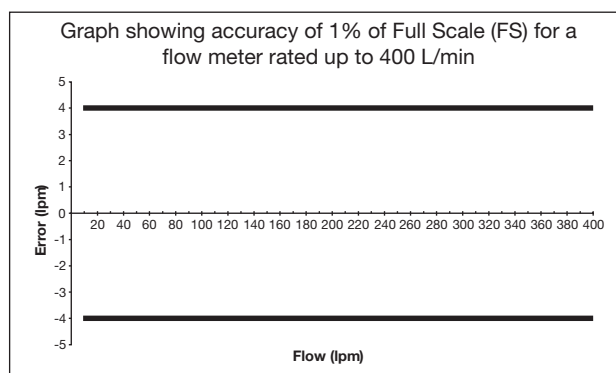

Indicated reading (IR)

Accuracy is quoted as a percentage of the actual value measured. So if the accuracy of a 400 L/min flow meter is 1% IR then the error at 400 L/min is ± 4 L/min. As the actual flow measured reduces, so does the error in L/min. When measuring a flow of 60 L/min with an accuracy of 1% IR, the possible error is ± 0.6 L/min. At very low flows, the possible errors are no longer proportional to

the flow rate, but actually a fixed amount in L/min (see graph below). For example if the accuracy is quoted as 1% IR (>60 L/min) for a flow meter with the range 10 - 400 L/min, then the accuracy is 1% of the actual flow in the range 60 to 400 L/min and a fixed flow error in the range 10 to < 60 L/min.

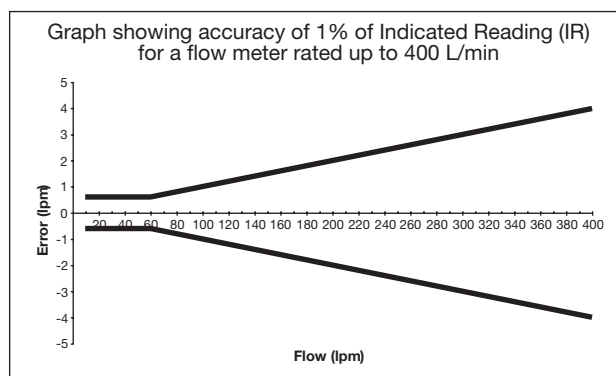

Repeatability

The repeatability is the variation in the performance of the flow meter when used under the same conditions. Our range of flow meters has excellent repeatability of better than $\pm 0.2\%$. This is just as important as the accuracy since in many applications the flow readings from the same flow meter will be compared at regular intervals to look for any change in performance of the system.

Flow range (Turndown ratio)

A turbine flow meter has a minimum and a maximum calibrated flow which together describe the range of flows that can be accurately measured. Through the addition of signal conditioning either mounted on the flow meter or built into the readout, the flow range of our flow meters has been extended considerably compared to other models on the market; the ratio of the maximum to the minimum calibrated flow (turndown ratio) is between 15 and 40 across all models. Particular effort has been made to extend the flow range by calibrating down to lower flows enabling one flow meter to be used where two may have been required in the past. This makes the flow meter both a more economical and easier to install solution.

Fluid viscosity

The performance of a turbine flow meter can be affected by the viscosity of the fluid measured. Our turbine flow meters are calibrated at between 18 and 26 cSt as standard (a mean viscosity of 21 cSt), which is the typical kinematic viscosity for a hydraulic fluid operating at 50 °C. The kinematic viscosity of all hydraulic fluids is related to the fluid temperature and the table below shows the affect of temperature on the kinematic viscosity of a range of typical grades of hydraulic oil.

The shaded area of the table shows the range of viscosities that can be measured by a flow meter with standard calibration with minimal effect on the accuracy (less than $\pm 1\%$ FS).

Flow meters can be specially calibrated at a different viscosity to the standard or we can advise on the expected error when the flow meter is used at other viscosities, please contact sales for further information.

Table showing kinematic viscosity (cSt) of different mineral oils at specific temperatures

TEMP °C	FLUID TYPE					
	ISO15	ISO22	ISO32	ISO37	ISO46	ISO68
0	85.9	165.6	309.3	449.6	527.6	894.3
10	49.0	87.0	150.8	204.7	244.9	393.3
20	30.4	50.5	82.2	105.5	127.9	196.1
30	20.1	31.6	48.8	59.8	73.1	107.7
40	14.0	21.0	31.0	36.6	44.9	63.9
50	10.2	14.7	20.8	23.9	29.4	40.5
60	7.7	10.7	14.7	16.5	20.2	27.2
70	6.0	8.1	10.9	12.0	14.6	19.2
80	4.8	6.4	8.4	9.1	11.1	14.3
90	4.0	5.2	6.6	7.2	8.7	11.1
100	3.3	4.3	5.5	6.0	7.1	8.9