

VFC Series

Variable Flow Pressure Compensated Control Valve

Variable Flow Control Valves maintain the flow rate of hydraulic fluid to a selected value.

Applications include hydraulic cylinders requiring constant extension or retraction speeds and hydraulic motors requiring constant rotational speeds. When used with a fixed delivery pump the excess flow is By-Passed across a relief valve.

Specifications

Maximum Pressure:	210 bar, 3000 psi
Maximum Flow:	55 L/min, 15 US gpm
Fluid Temperature Range:	-30 to 120 °C, -22 to 248 °F
Ambient Temperature Range:	-30 to 50 °C, -22 to 122 °F
Porting:	SAE, BSPP & NPTF
Materials: Body Materials:	Aluminium
Internal Materials:	Carbon Steel
Seals:	NBR, PTFE

Make it **BLUE**

Features

- Pressure compensated to ensure a constant flow rate under varying pressures
- Knurled knob enables fast, accurate adjustment of flow rate in one direction (under pressure) from 1.5 L/min to 55 L/min, 0.5 US gpm to 15 US gpm.
- Knurled knob can be locked in position by a socket (set) screw and provides weatherproof sealing to prevent the adjusting screw from corroding or seizing.
- Free (uncontrolled) flow is permitted in reverse direction.

ISO Symbol

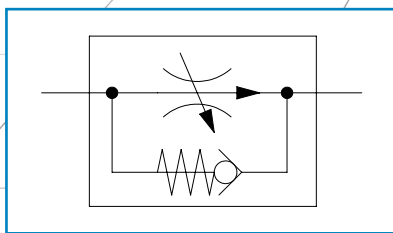

Sales Order Code

Please contact our technical sales team to discuss any special order requirements.

TYPICAL CODE	DESCRIPTION	SEE TABLE	YOUR CODE
VFC	Variable Flow Control	-	VFC
20	Flow Size	Table 1	
K	Adjustment Method (Knurled Knob)	-	K
J	Porting	Table 2	

Table 1: Valve Model

CODE	Flow Size	
	L/min	US gpm
20	1.5 - 20	0.5 - 5
40	2.0 - 40	0.5 - 10
55	2.0 - 55	0.5 - 15

Table 2: Porting

CODE	Flow Size Code	Porting
J	20	1/4" BSPP
	40	3/8" BSPP
	55	1/2" BSPP
A	20	1/4" NPTF*
	40	3/8" NPTF*
	55	1/2" NPTF*
G	20	7/16" -20UN #4 SAE ORB
	40	9/16" -18UN #6 SAE ORB
	55	3/4" -16UN #8 SAE ORB

* All NPTF threads are to ANSI B1.20.3 -1976 Class 1. As stated in the standard it is recommended that "sealing is accomplished by the means of a sealant applied to the thread". NPT fittings may also be used to connect to NPTF ports (also with a sealant applied to the thread).

Reverse Flow Typical Pressure Drop

All tests completed using ISO32 Mineral oil at 40 degrees C (32 cSt)

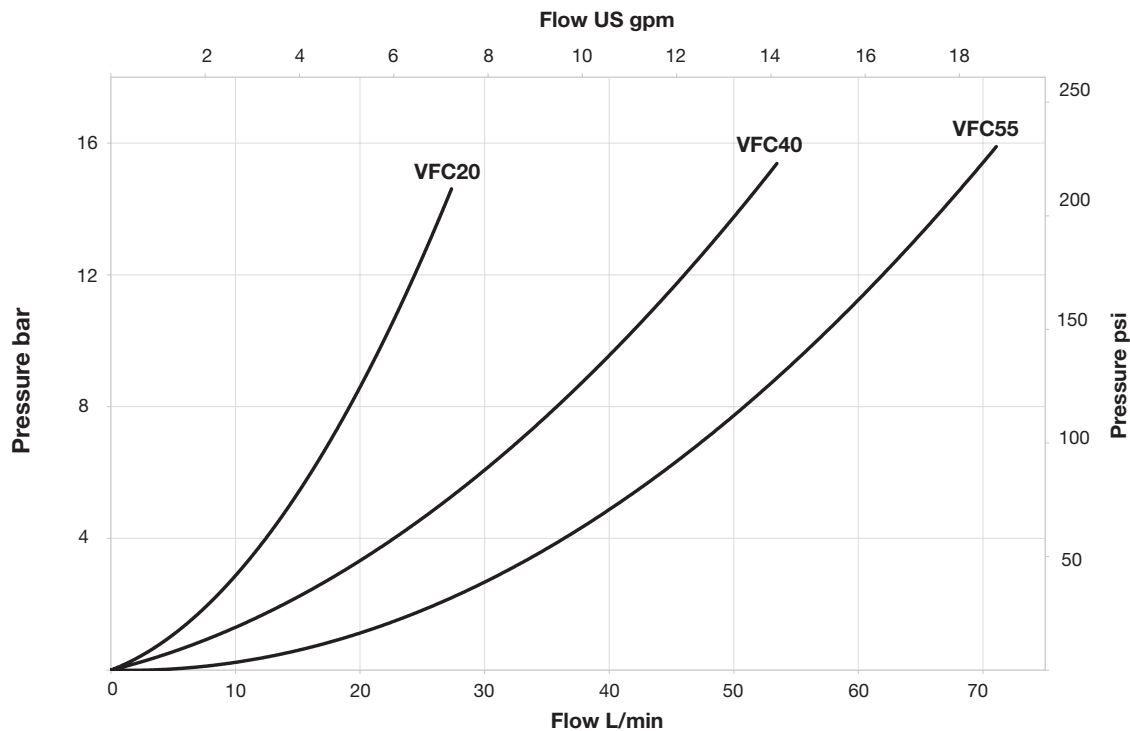

VFC40 Typical Performance Data

All tests completed using ISO32 Mineral oil at 40 degrees C (32 cSt)

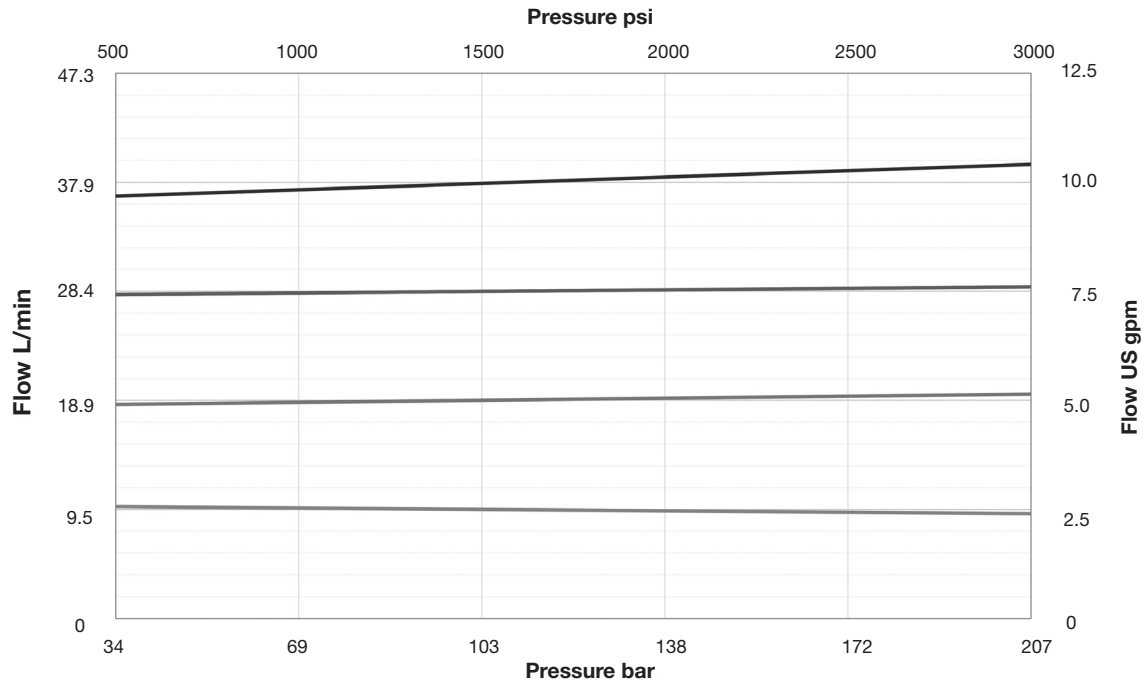

Installation Details

Table Dimensions

FLOW SIZE CODE	A		B		C		D		E		F		H		WEIGHT	
	mm	in	mm	in	mm	in	mm	in	mm	in	mm	in	mm	in	kg	lb
20	69.5	2.74	19.1	0.75	32.9	1.30	25.0	0.98	44.5	1.75	86.0	3.39	28.5	1.12	0.2	0.4
40	84.4	3.32	24.0	0.94	44.0	1.73	35.3	1.40	57.1	2.25	107.0	4.21	38.1	1.50	0.4	0.9
55	86.3	3.40	24.0	0.94	49.0	1.93	38.1	1.50	63.5	2.50	118.5	4.67	42.4	4.67	0.5	1.1

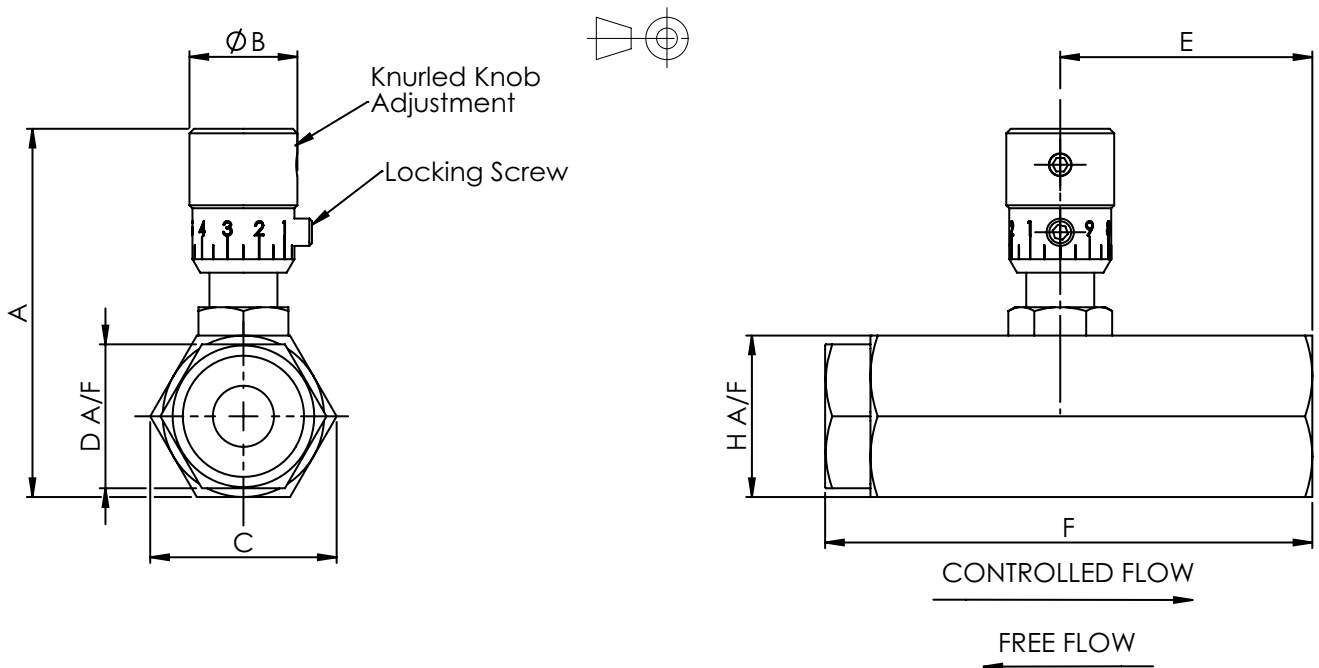

Webtec® reserve the right to make improvements and changes to the specification without notice
 Webtec®, Make it BLUE®, FlowHUB®, ViscoCorrect®, Interpass® and QuickCert® are registered trademarks of Webtec Products Limited.